

BAR BLENDER #33



A compact and efficient blender

This small commercial bar blender is designed to make all kinds of hot or cold preparations, such as soups, sauces, smoothies or cocktails.

Designed to last, this appliance is equipped with a bowl detection which preserves the coupling system.

Compact and easy to use, this appliance is ideal for bars, hotels and restaurants.

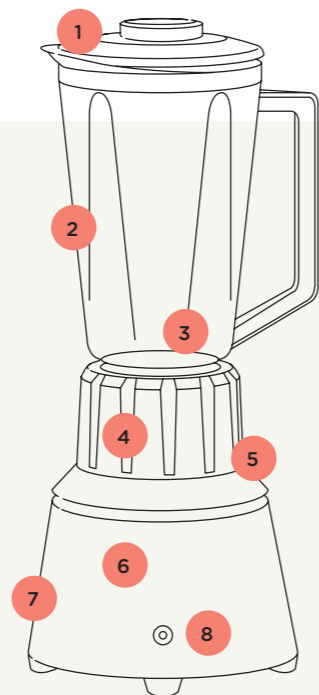

- 1 **Cover with filler-cap** to add ingredients while blending
- 2 **Graduated container:** 1,25 L (42oz)
- 3 **Stainless steel blades:** high resistance
- 4 **Long lasting couplings**
- 5 **Bowl detection:** motor stops when the bowl is removed
- 6 **Powerful and heavy duty commercial motor** (600W)
- 7 **Aluminium base**
- 8 **2 speeds:** 13 000 and 16 000 rpm



Professional quality

Heavy duty and reliable motor (600 W).
Bowl detection preserving the coupling system: motor stops when the bowl is removed from the base.
Strong stainless steel blades, with reinforced aluminium cutting assembly.

Easy to use and maintain

2 speeds for an easy control of your preparation.
Filler-cap to add ingredients while blending.
Quick coupling of container on motor base.
 Removable parts **for easy cleaning**.

Safety, Standards, Hygiene

In accordance with the following regulations	Machinery directive 2006 / 42 / EC
	Electromagnetic compatibility 2014 / 30 / EU
	“Low voltage” directive 2014 / 35 / EU
	RoHS directive 2011 / 65 / EU
Harmonized European Standards	EN ISO 12100: 2010
	NF EN 12852 + A1:2010
	EN 60204-1 + A1: 2009
Thermal Safety	EN 60335-2-64: 2004 Commercial electric kitchen machines
	CE Marking
	Motor protected by internal thermal detector
Electrical Safety	Regulation 1935 / 2004 / EC (contact with food)
	Regulation 10 / 2011 / EU (Plastic in contact with food)
Acoustic Safety	Waterproof On/Off interlock switch
	All mechanical parts are ground connected
Hygiene	Appliances are 100% tested after assembly
	Silent and powerful motor
Hygiene	All removable parts can be put in a dishwasher or easily cleaned with hot soapy water.
	Bisphenol-free

Technical specifications

Motor
 Single phase:
 110-120 V – 50/60 Hz – 600 W – CE, RoHS
 220-240 V – 50/60 Hz – 600 W – CE, RoHS

2 speeds:
 13000 rpm and 16000 rpm

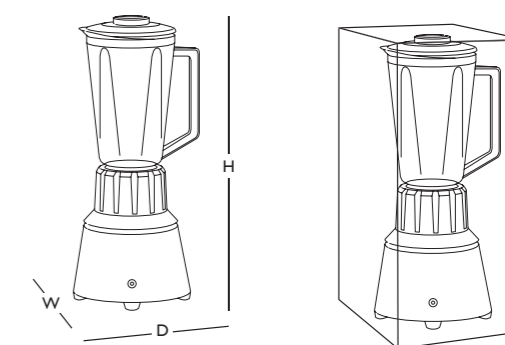

Appliance
 W: 180 mm (7")
 D: 180 mm (7")
 H: 420 mm (17")

Shipping box
 W: 210 mm (8")
 D: 230 mm (9")
 H: 475 mm (19")

Net Weight:
 3 Kg (6,6 lbs)

Packed weight:
 3,6 Kg (7,9 lbs)

Choose the blender adapted to your needs

Thanks to the wide range of Santos blenders, you can make all sorts of drinks, cocktails, soups...



PRODUCT: 2 YEAR WARRANTY

